

WINDING CONSTANTS *	UNITS	TOL	SYMBOL	WDG
DC RESISTANCE	OHMS	±12.5%	R	0.466
VOLTAGE @ T _p	VOLTS	NOMINAL	V _p	3.00
CURRENT @ T _p	AMPERES	NOMINAL	I _p	6.44
TORQUE SENSITIVITY	Nm/AMP	±10%	K _T	0.0087
	OZ-IN/AMP	±10%		1.23
BACK EMF CONSTANT	V/(RAD/SEC)	±10%	K _B	0.0087
INDUCTANCE	MILLI-HENRY	±30%	L	0.165

MOTOR PARAMETERS *	UNITS	SYMBOL	NOM. VALUE
PEAK TORQUE	Nm	T _p	0.056
	OZ-IN		8.00
CONTINUOUS STALL TORQUE **	Nm	T _{cs}	0.045
	OZ-IN		6.33
MOTOR CONSTANT	Nm/√WATT	K _M	0.0127
	OZ-IN/√WATT		1.80
ELECTRICAL TIME CONSTANT	MILLI-SEC	τ _E	0.35
MECHANICAL TIME CONSTANT	MILLI-SEC	τ _M	5.45
POWER I ² R @ T _p	WATTS	P _p	19.3
DAMPING FACTOR (ZERO IMPEDANCE)	Nm/(RAD/SEC)	F _o	1.62x10 ⁻⁴
	OZ-IN/(RAD/SEC)		0.023
ROTOR INERTIA	Kg m ²	J _M	8.83x10 ⁻⁷
	OZ-IN-SEC ²		1.25x10 ⁻⁴
THEO. NO-LOAD SPEED @ 70 VDC	RPM	S _M	76,848
MIN. SPEED AT 0.015 Nm & 70 VDC	RPM	S _L	70,000
2.124 OZ-IN & 70 VDC			
THEORETICAL ACCELERATION @ T _p	RAD/SEC ²	α _T	6.4x10 ⁴
THERMAL RESISTANCE	°C/WATT	θ _{TH}	7.0
MAX. ALLOWABLE WINDING TEMPERATURE	°C	TEMP	155
NUMBER OF PHASES/WINDING TYPE			3/Y
NUMBER OF POLES			4
WEIGHT	GRAMS	W _T	TBD
	OZ		TBD

* 25°C AMBIENT TEMPERATURE
 ** 25°C AMBIENT, 155°C WINDING TEMPERATURE

LEAD WIRE: TEFLON TYPE E
 3X #22 AWG
 7X #28 AWG
 200 [7.9] MIN. LONG

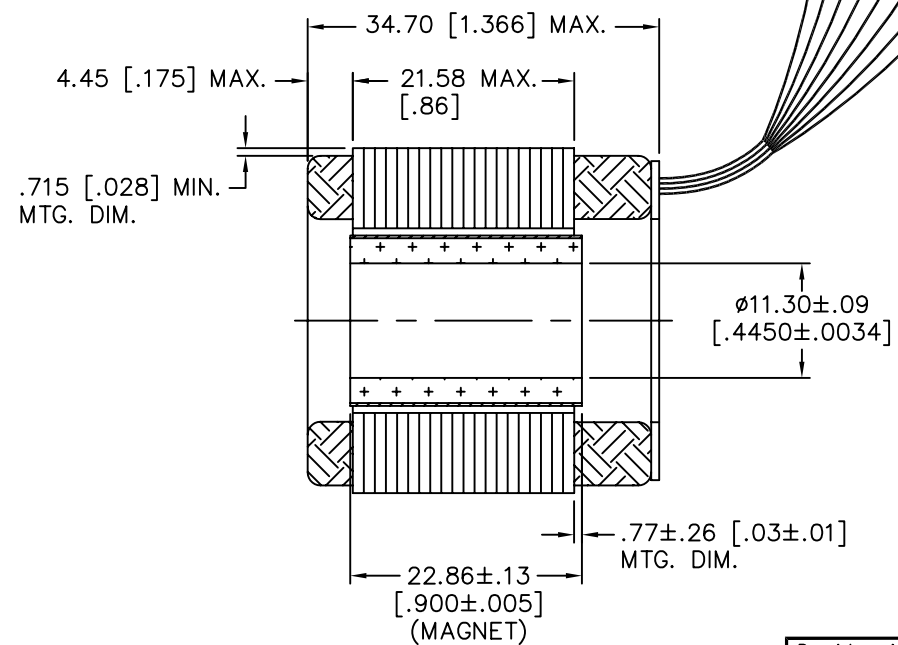

SECTION A-A

MOTOR LEADS	A	B	C
RED	+	+	-
BLK	-	+	+
GRN	-	-	+

HALL SENSOR LEADS	1	2	3	4	5	6
BRN	1	1	0	0	0	1
BLU	0	1	1	1	0	0
ORG	0	0	0	1	1	1

THERMAL SENSOR LEADS	Vcc+	GND	+	-
YEL				
GRY				
WHT				

METRIC DRAWING

Proprietary rights of BEI Kimco are involved in the subject matter of this material and all manufacturing, reproduction, use, and sales pertaining to such subject matter are expressly reserved. This confidential and proprietary document is submitted for a specified purpose, and the recipient by accepting this material agrees that this material will not be used, copied, or reproduced in whole or in part nor its contents revealed in any manner or to any person except to meet the purpose for which it was delivered.

THIRD ANGLE PROJECTION
 UNLESS OTHERWISE SPECIFIED:
 -ALL DIMENSIONS ARE IN MILLIMETERS
 -BREAK SHARP EDGES 0.4 MAX.
 -SURFACE ROUGHNESS √1.6
 -DIMENSIONS APPLY AFTER FINISH
 -MAX FILLET R 0.4
 -DIAMETERS SHALL NOT EXCEED A ROUNDOFF OF 0.13 FIM

TOLERANCES:
 DECIMALS ANGULAR
 .X ± 0.8 °0' 30'
 .XX ± 0.25
 .XXX ± 0.13
 DO NOT SCALE DRAWING

BEI KIMCO MAGNETICS DIVISION
 VISTA, CA 92081

DRAWN McGHEE	DATE 01/27/10	TITLE BLDC MOTOR PARTS SET
MECH CHECK J. THOMPSON	DATE 01/28/10	
APPD B. Du	DATE 01/28/10	
FILE NO. M:\TOP LEVEL\DIP\...	SIZE C	FSCM NO. 55789
	DWG NO. DIP14-14-000A	REV A
	SCALE: NONE	SHEET SHEET

4. MOTOR HAS 100Ω THERMAL SENSOR (MINCO P/N: S1000144PD12).
 3. ALL ABBREVIATIONS IAW ASME Y14.38.
 2. INTERPRET DRAWING IAW ASME Y14.100.
 1. INTERPRET DIMENSIONING AND TOLERANCING IAW ASME Y14.5M-1994.
- NOTES: UNLESS OTHERWISE SPECIFIED

LTR	ECO NO.	DESCRIPTION	DRN	APP'D	DATE
A	100015	INITIAL RELEASE	SLM	BD	01/28/10

BACK EMF AND SENSOR WAVEFORMS
 (ROTATION OF MOTOR = COUNTER CLOCKWISE FACING LEAD SIDE)

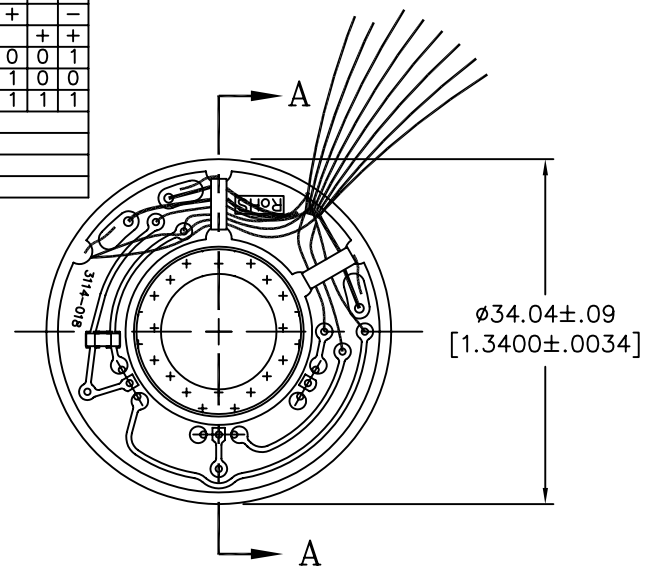
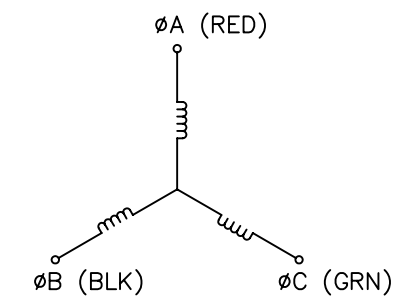
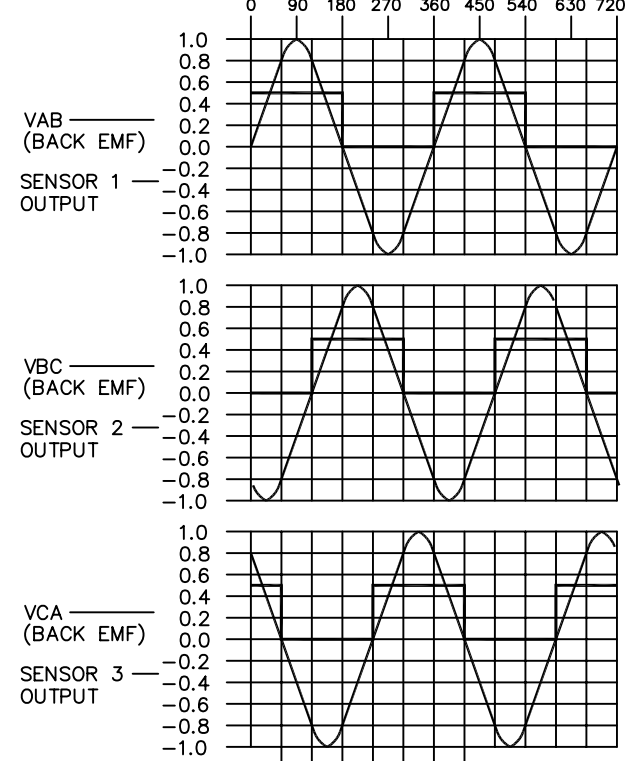

DIP14-14-000A