

WINDING CONSTANTS	UNITS	TOL	SYM	WDG A	WDG B	WDG C	WDG D	WDG E
DC RESISTANCE	OHMS	±12.5%	R	1.9	4.6	11.5	18.1	45.6
VOLTAGE @ T _p	VOLTS	NOMINAL	V _p	18.2	28.7	46.2	58.1	93.4
CURRENT @ T _p	AMPERES	NOMINAL	I _p	9.6	6.2	4.0	3.2	2.0
TORQUE SENSITIVITY	OZ IN/AMP	±10%	K _T	4.5	6.9	10.7	13.4	21.0
BACK EMF CONSTANT	VOLTS/(RAD/SEC)	±10%	K _B	0.032	0.049	0.076	0.095	0.148
INDUCTANCE	MILLIHENRY	±30%	L	0.95	2.3	5.8	9.1	22.8

LTR	ECO NO.	DESCRIPTION	DRN	APP'D	DATE
C	97-0668	UPDATE BORE DIA & TOL	RLE	HP	05/21/97
D	070564	ADD WAVEFORM	SLM	BD	09/18/07

MOTOR PARAMETERS	UNITS	SYM	NOM. VALUE
PEAK TORQUE *	OZ IN	T _p	43.0
CONTINUOUS STALL TORQUE **	OZ IN	T _{CS}	9.5
MOTOR CONSTANT	OZ IN/√WATT	K _M	3.3
ELECTRICAL TIME CONSTANT	MILLISECOND	τ _E	0.50
MECHANICAL TIME CONSTANT	MILLISECOND	τ _M	12.3
POWER I ² R @ T _p	WATTS	P _p	173.5
DAMPING FACTOR (ZERO IMPEDANCE)	OZ IN/(RAD/SEC)	F ₀	0.076
BREAKAWAY TORQUE	OZ IN	T _F	1.2
ROTOR INERTIA	OZ IN SEC ²	J _M	9.1x10 ⁻⁴
MAX ALLOWABLE SPEED	RPM	S _M	12,000
SPEED @ OZ-IN & VDC	RPM	S _L	
THEO ACC @ T _p	RAD/SEC ²	α _T	4.4x10 ⁴
THERMAL RESISTANCE ***	°C/WATT	θ _{TH}	9.5
MAX ALLOWABLE WINDING TEMP	°C	TEMP	155
NUMBER OF PHASES/WINDING TYPE			3/Y
NUMBER OF POLES			8
WEIGHT	OZ	W _T	4.5

* 10 SEC @ 25°C AMBIENT TEMP
 ** 25°C AMBIENT, 155° WINDING TEMP
 *** WITH ALUMINUM HOUSING HEATSUNK TO 8 X 8 X 1/8 INCH ALUMINUM PLATE

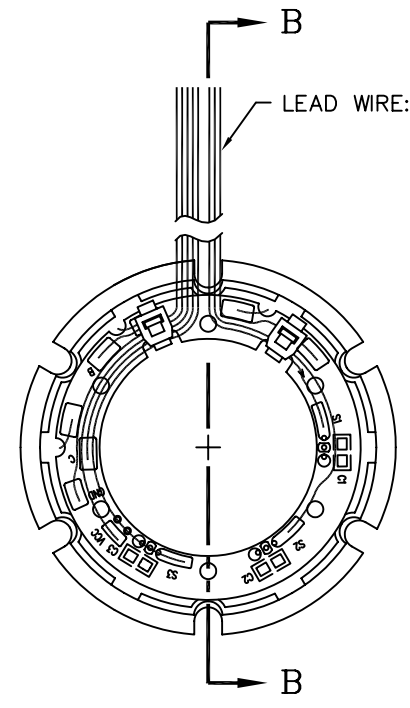
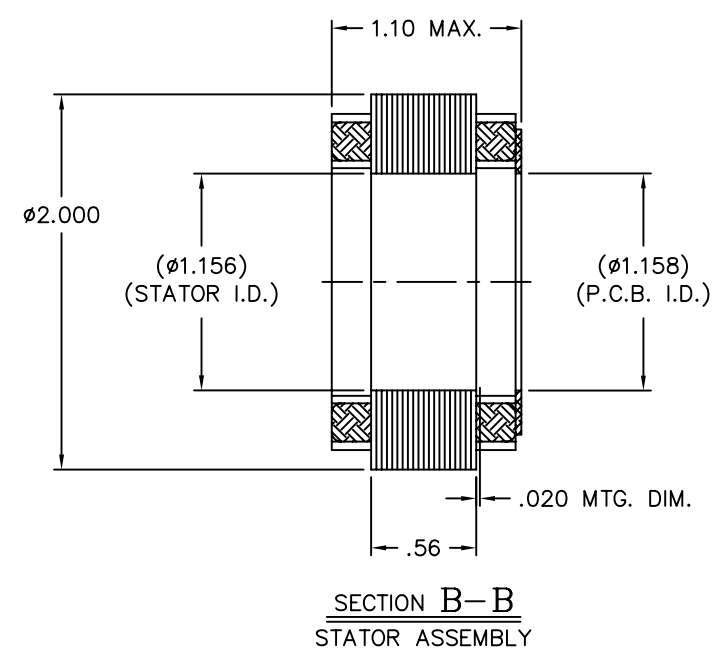
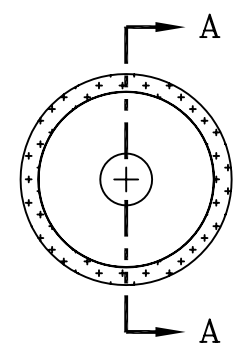
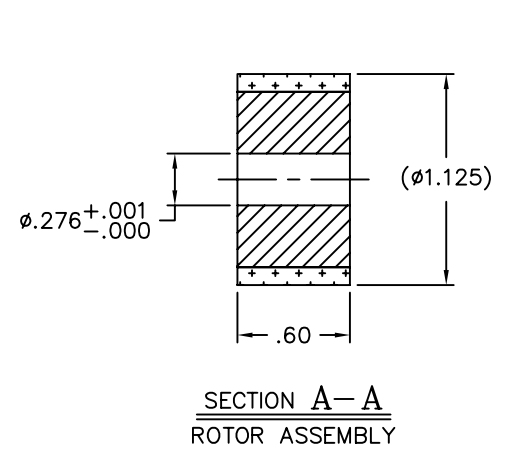

LEAD WIRE: PVC UL #1061 80°C
 3x #22 AWG
 5x #28 AWG
 12.0 MIN. LONG

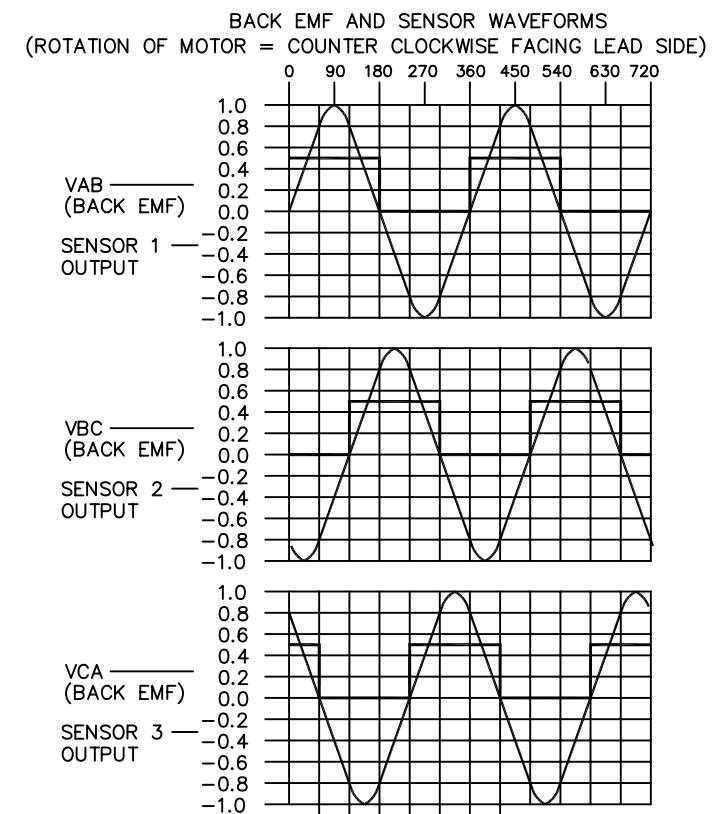

MOTOR LEADS	COLOR	1	2	3	4	5	6
A	RED	+	+	-	-		
B	BLK	-	-	+	+		
C	GRN					+	+
1	BRN	1	1	0	0	0	1
2	BLU	0	1	1	1	0	0
3	ORG	0	0	0	1	1	1
Vcc+	YEL						
GND	GRY						

Proprietary rights of BEI Kimco are involved in the subject matter of this material and all manufacturing, reproduction, use, and sales pertaining to such subject matter are expressly reserved. This confidential and proprietary document is submitted for a specified purpose, and the recipient by accepting this material agrees that this material will not be used, copied, or reproduced in whole or in part nor its contents revealed in any manner or to any person except to meet the purpose for which it was delivered.

THIRD ANGLE PROJECTION

UNLESS OTHERWISE SPECIFIED:
 -ALL DIMENSIONS ARE IN INCHES
 -BREAK SHARP EDGES .015 MAX.
 -SURFACE ROUGHNESS √63
 -DIMENSIONS APPLY AFTER FINISH
 -MAX FILLET R .010

TOLERANCES:
 DECIMALS ANGULAR
 .X ± .03 ±0° 30'
 .XX ± .01
 .XXX ± .005

DO NOT SCALE DRAWING

BEI KIMCO MAGNETICS DIVISION
 VISTA, CA 92081

DRAWN R. ELLIOTT	DATE 09/21/92	TITLE BLDC MOTOR PART SET	
MECH CHECK McGHEE	DATE 09/18/07	SIZE B	FSCM NO. 55789
APPD HA PHAM	DATE 09/23/92	DWG NO. DIP20-09-HPZ(LTR)	REV D
FILE NO. M:\TOPLEVEL\DIP\...	SCALE 1/1	SHEET 1 OF 1	