

WINDING CONSTANTS *	UNITS	TOL	SYMBOL	MDG A
DC RESISTANCE	OHMS	±12.5%	R	6.7
VOLTAGE @ I_p	VOLTS	NOMINAL	V _p	26.8
CURRENT @ I_p	AMPERES	NOMINAL	I _p	4.0
FORCE SENSITIVITY	LB/AMP	±10%	K _F	4.0
	N/AMP	±10%		17.8
BACK EMF CONSTANT	V/FT/SEC	±10%		5.42
	V/M/SEC	±10%	K _B	17.8
INDUCTANCE ****	MILLI-HENRY	±15%	L	3.1

LR#	EDD NO.	DESCRIPTION	REV	DATE
E	060276	RAHS COMPLIANT	INT	4/21/06
F	060736	CHGD INDUCTANCE & ELECT TIME CONSTANT	INT	6/25/06
G	070201	CORRECT WEIGHT PARAMETERS	INT	3/23/07

ACTUATOR PARAMETERS *	UNITS	SYMBOL	VALUE
PEAK FORCE **	LB	F _p	16.0
	N		71.2
CONTINUOUS STALL FORCE ***	LB	F _{cs}	6.4
	N		28.5
ACTUATOR CONSTANT	LB/-WATT	K _A	1.55
	N/-WATT		6.9
ELECTRICAL TIME CONSTANT	MILLI-SEC	T _e	.48
MECHANICAL TIME CONSTANT	MILLI-SEC	T _m	1.7
POWER FR @ F _p	WATTS	P _p	107.2
STROKE	± INCHES		0.300
	± MM		7.6
CLEARANCE ON EACH SIDE OF COIL	MM		0.015
	IN		0.36
THERMAL RESISTANCE OF COIL	°C/WATT	θ _{JH}	5.0
MAX ALLOWABLE COIL TEMP	°C	TEMP	155
WEIGHT OF COIL ASSEMBLY ****	G	WT _G	2.92
	LB		0.064
WEIGHT OF FIELD ASSEMBLY	G	WT _F	14.6
	LB		0.323

* AT MID-STROKE & 25° AMBIENT TEMPERATURE
 ** 10 SECONDS AT 25°C AMBIENT & 155°C COIL TEMPERATURE
 *** 25°C AMBIENT & 155°C WINDING TEMPERATURE
 **** MEASURED AT 1000 Hz

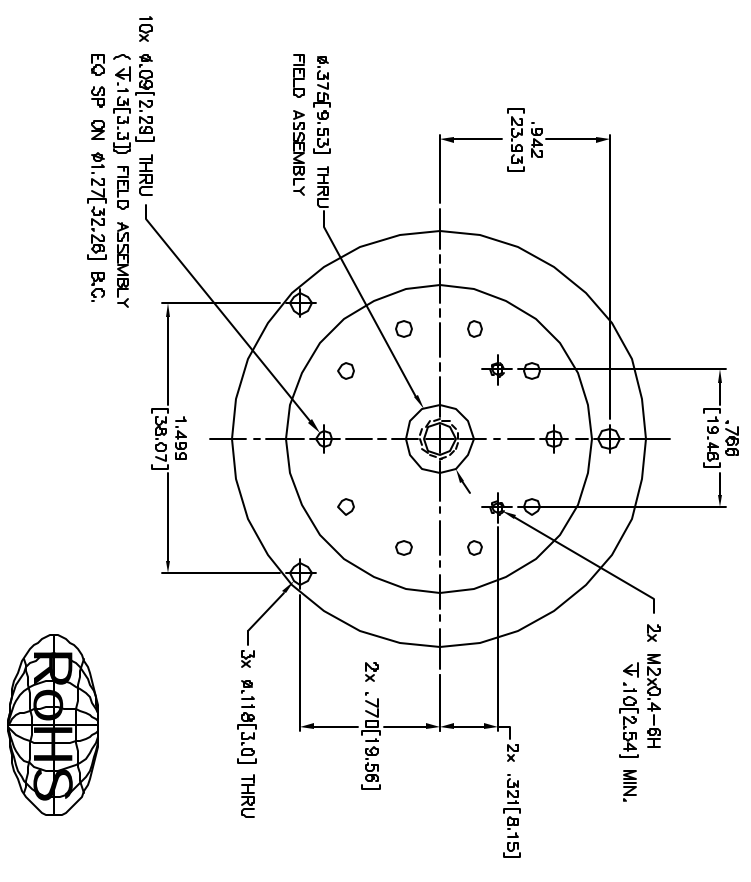
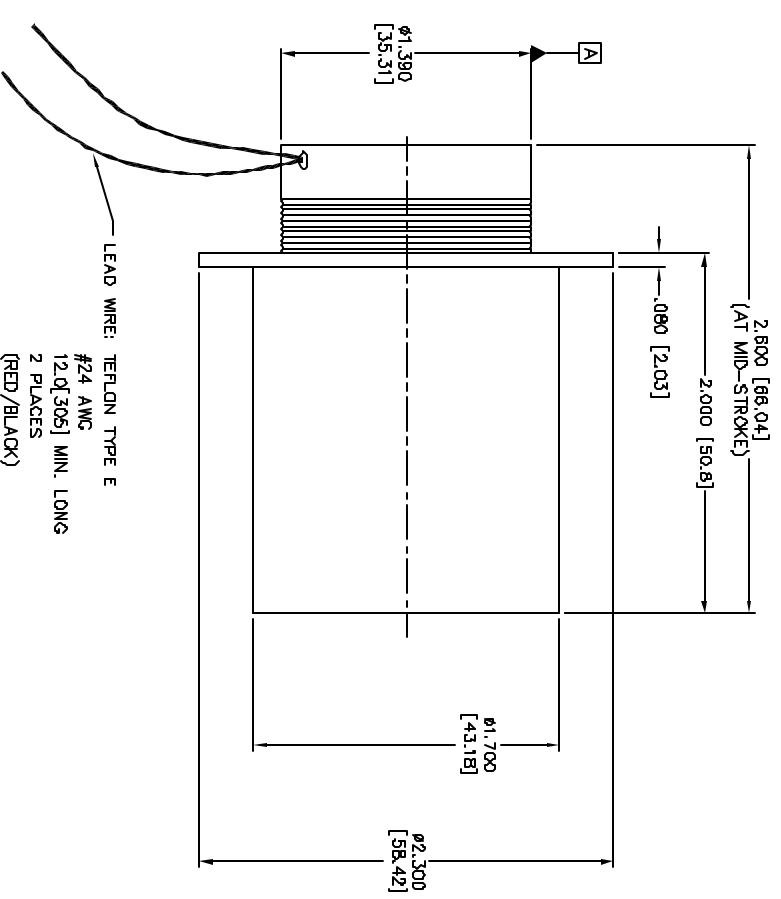
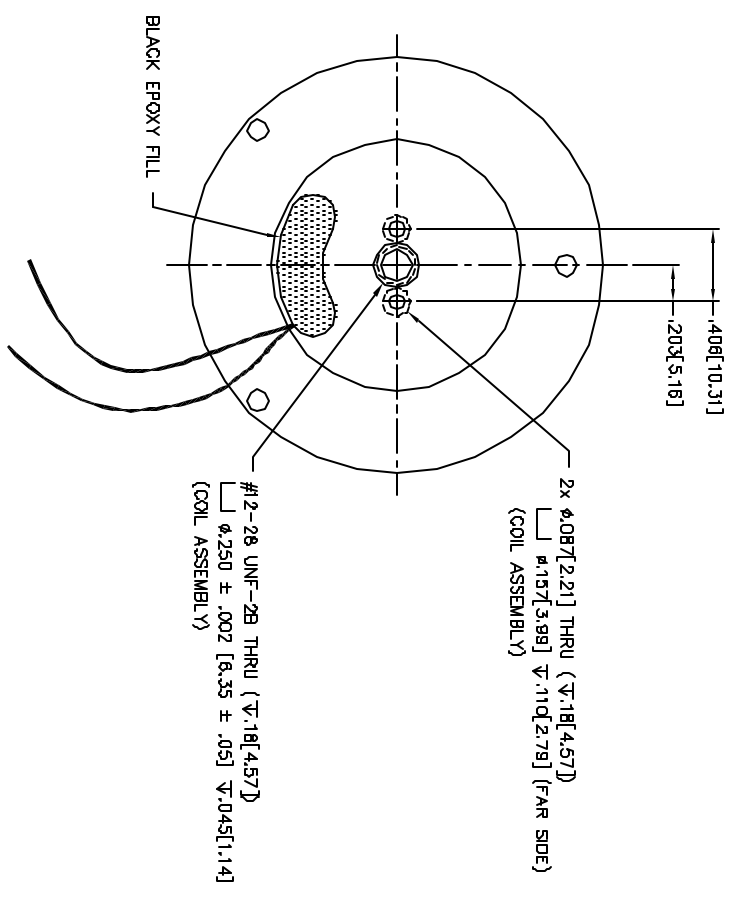
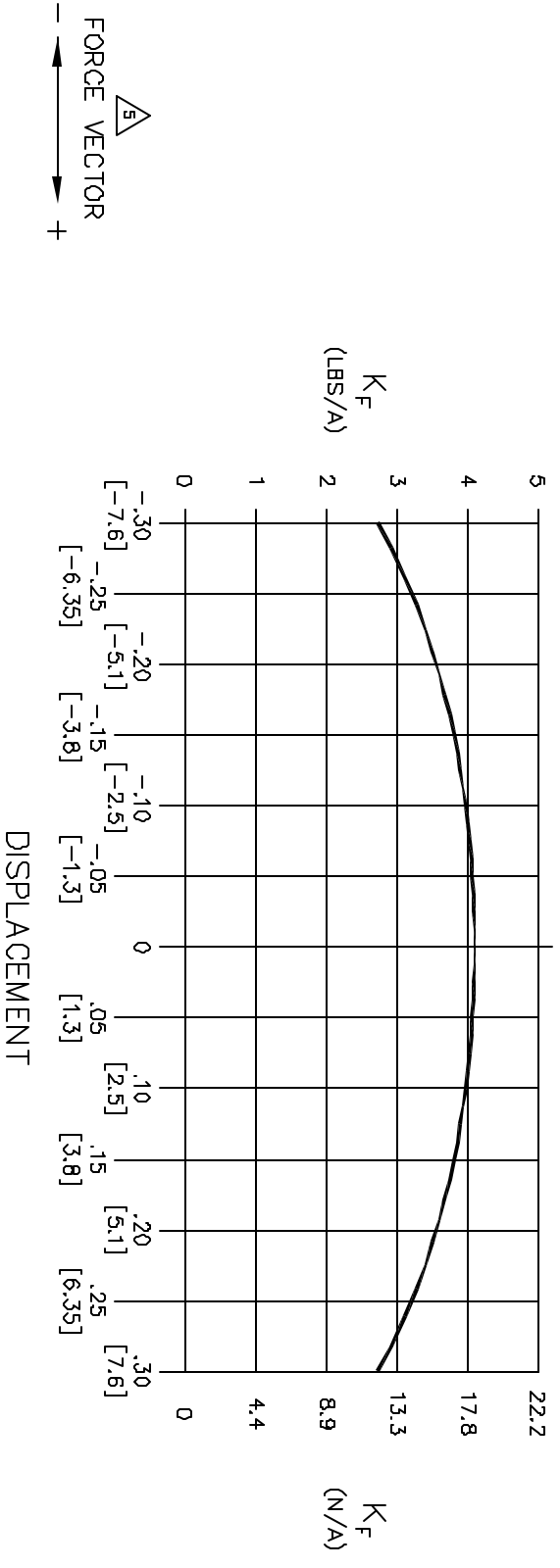

- MECHANICAL OVERTRAVEL IN THE POSITIVE (+) DIRECTION IS .015 [38] MIN.
- A POSITIVE (+) VOLTAGE APPLIED TO THE BLACK LEAD WILL PRODUCE A FORCE ON THE COIL ASSEMBLY IN THE POSITIVE (+) DIRECTION.
- DIMENSION IN BRACKETS ARE IN MILLIMETERS [MM] AND ARE FOR REFERENCE ONLY.
- ALL ABBREVIATIONS IAW MIL-STD-12.
- INTERPRET DRAWING IAW MIL-STD-100.
- INTERPRET DIMENSIONING AND TOLERANCING IAW ASME Y14.5M-1994.

NOTES: UNLESS OTHERWISE SPECIFIED

BEI KIMCO MAGNETICS DIVISION
 VISTA, CA 92081

THIRD ANGLE PROJECTION	DATE	TIME
<input checked="" type="checkbox"/>	04/02/96	

DESCRIPTION	DATE	TIME	REV
B BUTTERFIELD	04/02/96		
REVISIONS	01/29/06		
DESIGNED BY	AMOROS	04/02/96	
CHECKED BY	AMOROS	04/02/96	
APPROVED BY	AMOROS	04/02/96	
DATE	04/02/96		
TIME			
REV			

LA17-28-000A

A