

Winding Constants *	Units	Tol	Symbol	Wdg	A
DC Resistance	Ohms	± 12.5%	R	2.4	
Voltage @ F _P	Volts	Nominal	V _P	31.6	
Current @ F _P	Amps	Nominal	I _P	13.16	
Force Sensitivity	N/Amp	± 10%	K _F	20.28	
	LB/Amp	± 10%		4.56	
Back EMF Constant	V/(m/sec)	± 10%	K _B	20.28	
	V/(ft/sec)	± 10%		6.18	
Inductance ****	milli-henry	± 30%	L	3.15	

LTR	ECO NO.	DESCRIPTION	DRN	APP'D	DATE
X1	090107	INITIAL RELEASE	SLM	MG	04/23/09
X2	100328	REMOVE ANTI-ROTATION PIN	SLM	MG	11/11/10

Linear Actuator Parameters *	Units	Symbol	Value
Peak Force **	N	F _P	266.9
	LB		60
Continuous Stall Force ***	N	F _{CS}	75.6
	LB		17
Actuator Constant	N/√Watt	K _A	13.09
	LB/√Watt		2.94
Electrical Time Constant	milli-sec	τ _E	1.31
Mechanical Time Constant	milli-sec	τ _M	4.3
Theoretical Acceleration	m/sec ²	α _T	360.7
	ft/sec ²		1183.4
Max Theoretical Frequency @ Full Stroke & Sinusoidal/Triangular Motion	Hz	f _{max}	26.8/29.8
Power I ² R @ F _P	Watts	P _P	416
Stroke:	± mm		12.5
	± in		0.492
Clearance on Each side of Coil	mm		1.51
	in		0.02
Thermal Resistance of Coil in still air	°C/Watt	θ _{TH}	2.6
Maximum Allowable Coil Winding Temp	°C	Temp	155
Weight of Coil Assembly *****	Kg	WT _C	0.74
	LB		1.63
Weight of Field Assembly	Kg	WT _F	1.62
	LB		3.57

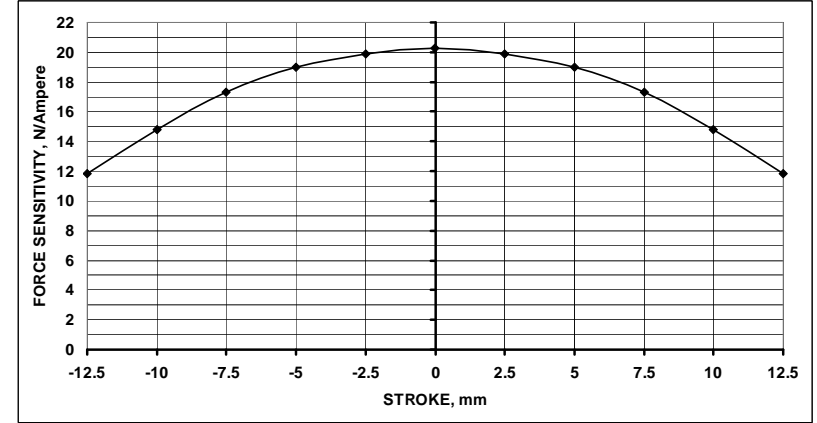

* AT MID-STROKE POSITION AND @ 25°C AMBIENT TEMPERATURE
 ** 10 SECONDS @ 25°C AMBIENT & 155°C COIL TEMPERATURE
 *** @25°C AMBIENT & 155°C COIL TEMPERATURE
 **** MEASURED AT 1000 Hz
 ***** PARAMETERS ARE GIVEN FOR -12S MODEL

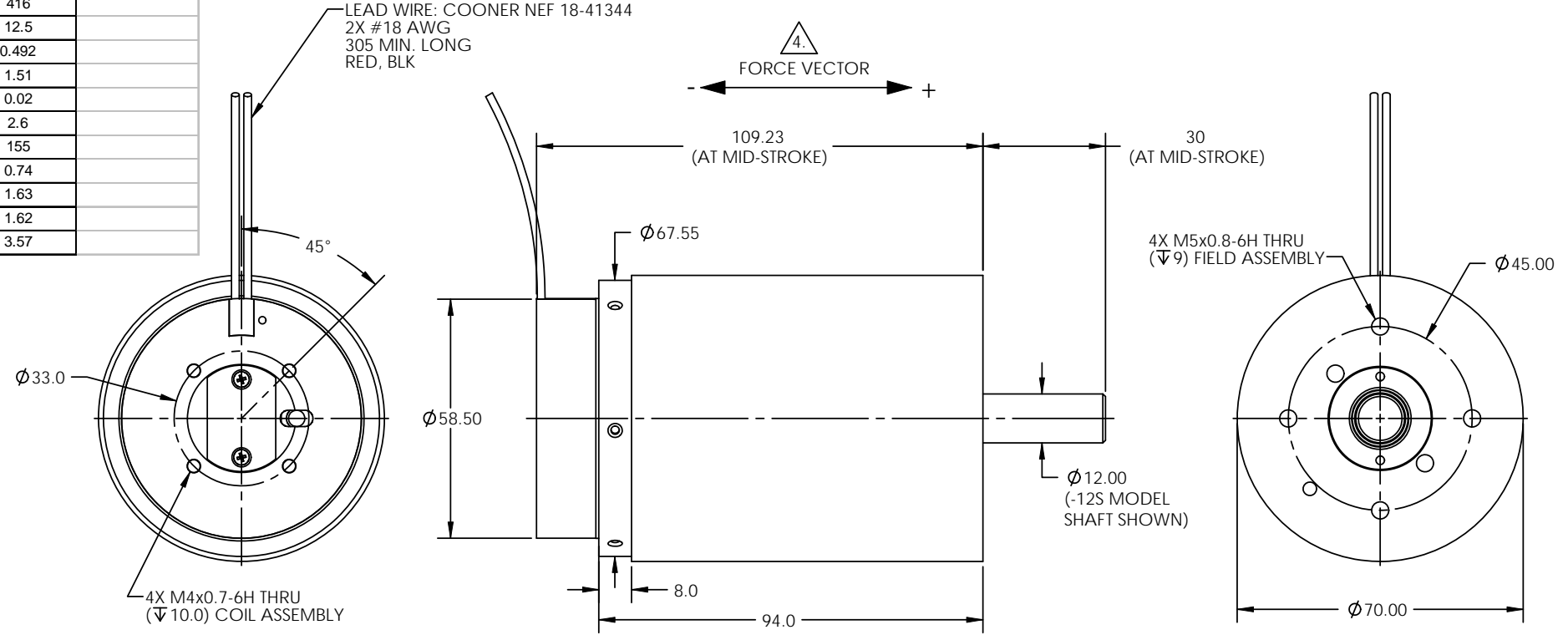

(DASH)#	DIA. OF SHAFT	SHAFT END CONFIGURATION
-12S	12mm	Standard (12mm)
-12E	12mm	External Thread M12x1.75 X 16mm Long
-12I	12mm	Internal Thread M8x1.0 X 16mm Deep

4. A POSITIVE (+) VOLTAGE APPLIED TO THE BLACK LEAD WIRE WILL PRODUCE A FORCE ON THE COIL ASSEMBLY IN THE POSITIVE (+) DIRECTION.
- ALL ABBREVIATIONS IAW ASME Y14.38.
 - INTERPRET DRAWING IAW ASME Y14.100.
 - INTERPRET DIMENSIONING AND TOLERANCING IAW ASME Y14.5M-1994.
- NOTES: UNLESS OTHERWISE SPECIFIED

THESE COMMODITIES, TECHNOLOGY OR SOFTWARE IF EXPORTED FROM THE UNITED STATES SHALL BE IN ACCORDANCE WITH THE EXPORT ADMINISTRATION REGULATIONS. DIVERSION CONTRARY TO U.S. LAW IS PROHIBITED

Proprietary rights of BEI Kimco are involved in the subject matter of this material and all manufacturing, reproduction, use, and sales pertaining to such subject matter are expressly reserved. This confidential and proprietary document is submitted for a specified purpose, and the recipient by accepting this material agrees that this material will not be used, copied, or reproduced in whole or in part nor its contents revealed in any manner or to any person except to meet the purpose for which it was delivered.

THIRD ANGLE PROJECTION

UNLESS OTHERWISE SPECIFIED:
 -ALL DIMENSIONS ARE IN MILLIMETERS
 -BREAK SHARP EDGES 0.4 MAX
 -SURFACE ROUGHNESS 1.6 ✓
 -DIMENSIONS APPLY AFTER FINISH
 -MAX FILLET R0.25
 -DIAMETERS SHALL NOT EXCEED A RUNOUT OF 0.13 FIM

TOLERANCES:
 DECIMALS: X ±0.8, .X ±0.25, .XX ±0.13
 ANGULAR: ±0°30'
 DO NOT SCALE DRAWING

METRIC DRAWING



BEI KIMCO MAGNETICS DIVISION
 VISTA, CA 92081

DRAWN McGHEE	DATE 04/08/09	TITLE LINEAR ACTUATOR	
CHECK GUERRERO	DATE 04/23/09	SIZE C	REV X2
APPD M. GODKIN	DATE 04/23/09	FSCM NO. 55789	DWG NO. LA28-43-001A-DASH
FILE NO. L:\TOP LEVEL\LA\...	SCALE: NONE	SHEET: 1 OF 1	