

LTR	ECO NO.	DESCRIPTION	DRN	APP'D	DATE
X7	110009	COIL ASSEMBLY O.D. 3.535 NOW 3.533	SLM	MG	01/18/11
X8	110104	ADDED RoHS LOGO	RG	MG	05/31/11

WINDING CONSTANTS	UNITS	TOL	SYMBOL	WDG A
DC RESISTANCE	OHMS	±12.5%	R	6.05
VOLTAGE @ F <sub>p</sub>	VOLTS	NOMINAL	V <sub>p</sub>	121.0
CURRENT @ F <sub>p</sub>	AMPERES	NOMINAL	I <sub>p</sub>	20.0
FORCE SENSITIVITY	LB/AMP	±10%	K <sub>F</sub>	15.5
	N/AMP	±10%		68.9
BACK EMF CONSTANT	V/FT/SEC	±10%	K <sub>B</sub>	21.0
	V/M/SEC	±10%		68.9
INDUCTANCE *****	MILLI-HENRY	±15%	L	4.57

ACTUATOR PARAMETERS*	UNITS	SYMBOL	VALUE
PEAK FORCE **	LB	F <sub>p</sub>	310.0
	N		1378.9
CONTINUOUS STALL FORCE ***	LB	T <sub>cs</sub>	63.6
	N		282.9
ACTUATOR CONSTANT	LB/√WATT	K <sub>A</sub>	6.3
	N/√WATT		28.02
ELECTRICAL TIME CONSTANT	MILLI-SEC	τ <sub>E</sub>	0.76
MECHANICAL TIME CONSTANT	MILLI-SEC	τ <sub>M</sub>	1.24
THEORETICAL ACCELERATION	FT/SEC	α <sub>T</sub>	9047.8
	M/SEC <sup>2</sup>		2757.8
MAXIMUM THEORETICAL FREQUENCY @ FULL STROKE (1.25")	Hz	f <sub>max</sub>	66.34
POWER I <sup>2</sup> R @ F <sub>p</sub>	WATTS	P <sub>p</sub>	2420.0
STROKE	± INCHES		0.625
	± MM		15.87
CLEARANCE ON EACH SIDE OF COIL	IN		0.02
	MM		0.51
THERMAL RESISTANCE OF COIL	°C/WATT	θ <sub>TH</sub>	0.85
MAX. ALLOWABLE COIL TEMP.	°C	TEMP	155
WEIGHT OF COIL ASSEMBLY	LB	WT <sub>C</sub>	1.1
	KG		0.5
WEIGHT OF FIELD ASSEMBLY	LB	WT <sub>F</sub>	17.4
	KG		7.89

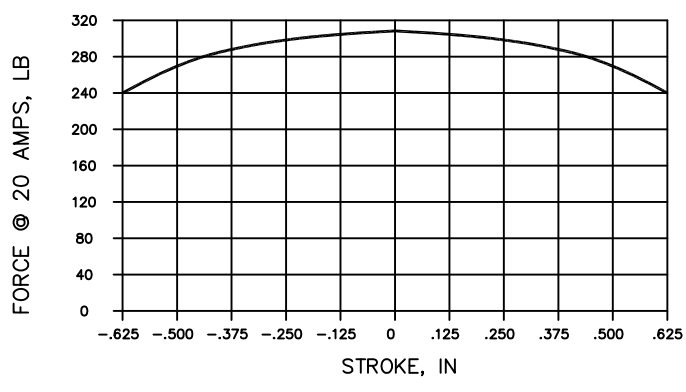

\* AT MID-STROKE & 25°C AMBIENT TEMPERATURE  
 \*\* 10 SECONDS AT 25°C AMBIENT & 155°C COIL TEMPERATURE  
 \*\*\* 25°C AMBIENT & 155°C COIL TEMPERATURE  
 \*\*\*\* MEASURED AT 1000 Hz

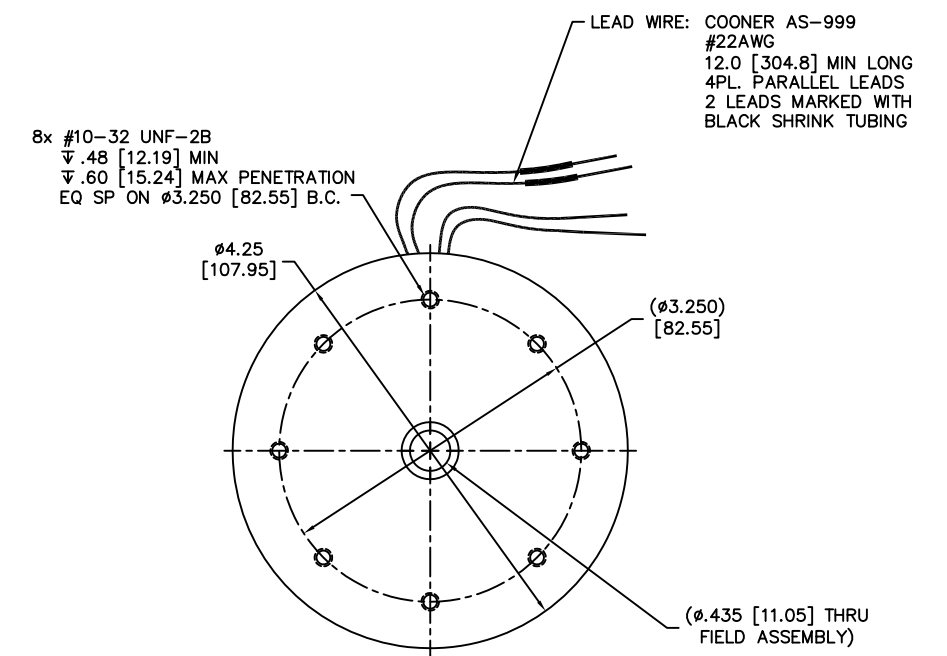
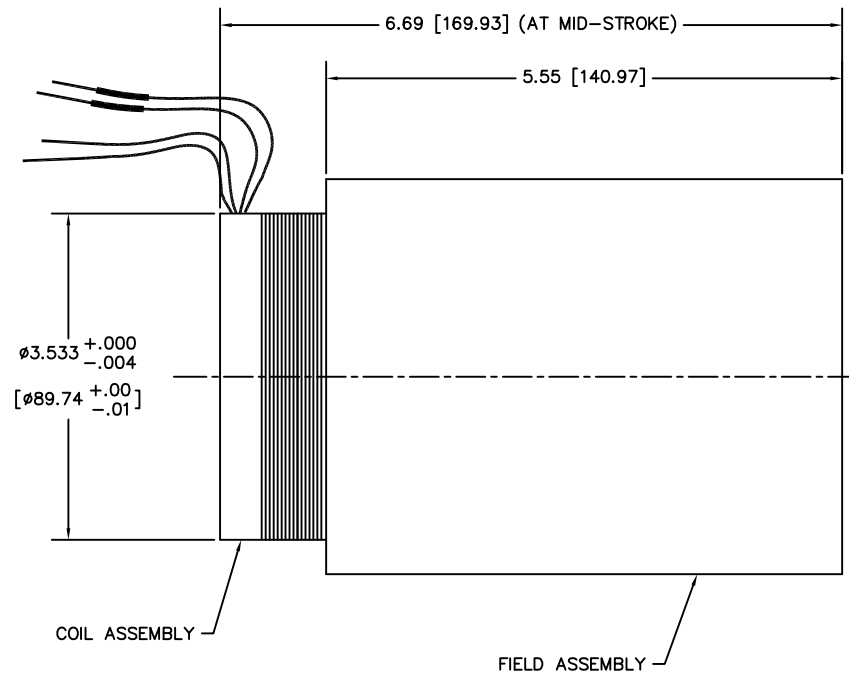
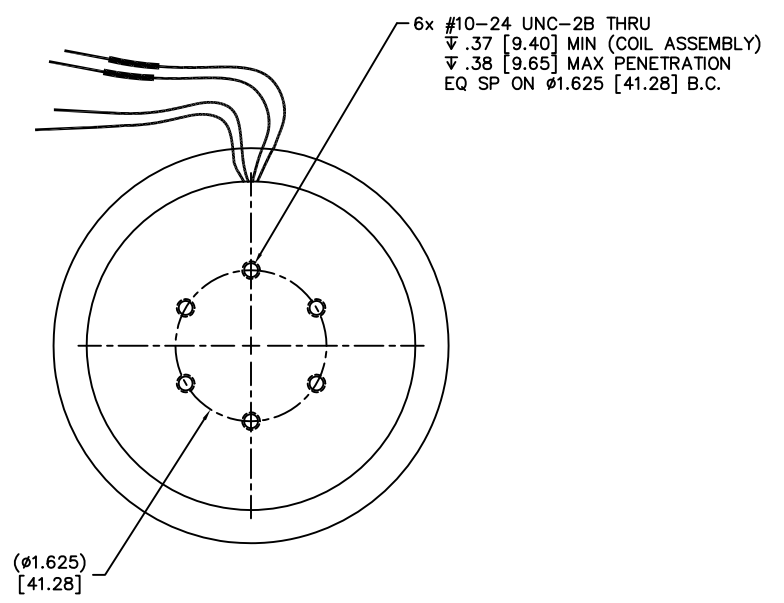
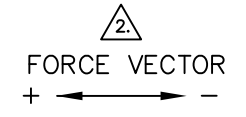

2. A POSITIVE (+) VOLTAGE APPLIED TO THE MARKED LEADS WILL PRODUCE A FORCE ON THE COIL ASSEMBLY IN THE POSITIVE (+) DIRECTION.

1. INTERPRET DIMENSIONS & TOLERANCES PER ASME Y14.5M-1994.

NOTES: UNLESS OTHERWISE SPECIFIED

U.S. PATENT NO.  
 5,345,206

THESE COMMODITIES, TECHNOLOGY OR SOFTWARE IF EXPORTED FROM THE UNITED STATES SHALL BE IN ACCORDANCE WITH THE EXPORT ADMINISTRATION REGULATIONS. DIVERSION CONTRARY TO U.S. LAW IS PROHIBITED.

Proprietary rights of BEI Kimco are involved in the subject matter of this material and all manufacturing, reproduction, use, and sales pertaining to such subject matter are expressly reserved. This confidential and proprietary document is submitted for a specified purpose, and the recipient by accepting this material agrees that this material will not be used, copied, or reproduced in whole or in part nor its contents revealed in any manner or to any person except to meet the purpose for which it was delivered.

THIRD ANGLE PROJECTION

UNLESS OTHERWISE SPECIFIED:  
 -ALL DIMENSIONS ARE IN UNITS  
 -BREAK SHARP EDGES 0.15 MAX.  
 -SURFACE ROUGHNESS √63  
 -DIMENSIONS APPLY AFTER FINISH  
 -MAX FILLET R FILLET

TOLERANCES:  
 DECIMALS ANGULAR  
 .X ± .X ANG.TOL  
 .XX ± .XX  
 .XXX ± .XXX  
 DO NOT SCALE DRAWING

DRAWN GUERRERO		DATE 06/01/05		TITLE LINEAR ACTUATOR	
MECH CHECK MCGHEE		DATE 06/02/05		SIZE D	
APPD M. GODKIN		DATE 06/02/05		FSCM NO. 55789	
FILE NO. L\TOP\LA\		DWG NO. LA43-67-000A		REV X8	
SCALE 1/1		SHEET 1 OF 1			



**BEI** KIMCO MAGNETICS DIVISION  
 VISTA, CA 92081